

MAXIMUM 954 KW (1280 HP) @ 2100 RPM [INTERMEDIATE DUTY]**STANDARD EQUIPMENT****MG-5301 DC**

Fresh and/or raw water heat exchangers

Input coupling 18"/21" – torsional type
with/without torsional stop

Oil pressure gauge

Oil strainer and oil filter

SAE No. '0'/'00' housings

SKF taper joints - output components

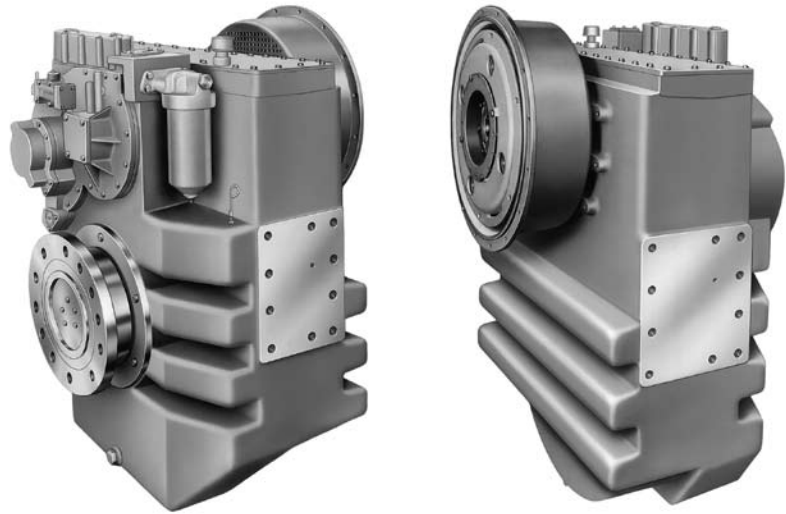
**OPTIONS**

12V or 24V electric selector valves

SAE 'C' 2 Bolt/4 Bolt PTO - 437 lb-ft Torque Capacity

Companion flange/bolt set

Less heat exchanger

Live SAE 'C-C' 2 Bolt/4 Bolt PTO -
875 lb-ft Torque Capacity

Metric to NPTF adapter kit

Mounting brackets

Oil temperature gauge/switch

PTOs (run at engine direction/speed)

Weight (dry weight - alloy housing)

MG-5301 DC**x****x****x****x****x****x****x****x****x****1405 kg***Contact Twin Disc for Survey Society Approvals and Classifications.**Specifications subject to change without prior notice in the interest of continual product improvement.***INPUT RATINGS – KILOWATTS (KW) (HORSEPOWER [HP])*****MG-5301 DC**

Reduction Ratios :1	Intermediate Duty		Continuous Duty			Max rated input speed and min. engine low idle speed RPM
	@ 1800 RPM	@ 2100 RPM	@ 1200 RPM	@ 1600 RPM	@ 1800 RPM	
1.17, 1.53, 1.76, 2.03, 2.48, 2.92	957 kW (1295 hp)	1127 kW (1511 hp)	597 kW (800 hp)	796 kW (1067 hp)	895 kW (1200 hp)	2400 max. 450 min.
3.48	835 kW (1120 hp)	975 kW (1307 hp)	-	712 kW (955 hp)	802 kW (1120 hp)	

* Ratings shown for use with standard right hand rotation engines.

SERVICE CLASSIFICATION DEFINITIONS

Pleasure Craft [PC]: Up to 500 hours/year, low load factor usage planing hull vessels where typical full engine throttle operation is less than 10% of total time. The balance of operation at 80% of full engine throttle or less. Marine transmissions for use in long range pleasure cruisers, sportfish charter boats/patrol boats do not qualify for Pleasure Craft Service.

Note: Some revenue producing applications such as Planing Hull Bristol Bay Gillnetter do qualify under Pleasure Craft rating definition.

Light Duty [LD]: Relatively low hour usage (less than 1500 hours per year) where full throttle operation is 2 hours out of 12.

Typical applications include planing hull vessels such as fire boats, sportfish charter boats, and patrol/custom boats. This rating is also applicable to some bow and stern thruster applications.

Intermediate Duty [ID]: Hour usage of up to 2000 hours/year (for models MG-5114 Series and smaller) and up to 3000 hours/year (for models larger than MG-5114 Series) with 50% of the operating time at full engine rating.

Typical applications include planing hull vessels such as ferries, fishing boats, some crew boats, and some displacement hull yachts as well as some bow and stern thruster applications.

Medium Duty [MD]: Hour usage of up to 4000 hours/year with up to 80% of operating time at full engine power. This duty classification is for usage where some variations in engine speed/power occur as part of normal vessel operation.

Typical vessels include mid-water trawlers, crew/supply boats, ferries, and some inland water tow boats.

Continuous Duty [CD]: For use in continuous operation with little or no variation in engine speed/power setting.

Typical vessels include fishing trawlers, tow/tug boats and ocean going vessels.

Important Notice: Torsional Vibration: Disregarding propulsion system torsional compatibility could cause damage to components in the drive train resulting in loss of mobility. At minimum, system incompatibility could result in gear clatter at low speeds.

The responsibility for ensuring that the torsional compatibility of the propulsion system is satisfactory rests with the assembler of the drive and driven equipment.

Torsional vibration analysis can be made by the engine builder, marine survey societies, independent consultants and others. Twin Disc is prepared to assist in finding solutions to potential torsional problems that relate to the marine transmission.

Twin Disc, Incorporated reminds users of these products that their safe operation depends on use in compliance with engineering information provided in this bulletin. Users are also reminded that safe operation depends on proper installation, operation and routine maintenance and inspection under prevailing conditions. It is the responsibility of the user (and not Twin Disc, Incorporated) to provide and install guards or safety devices which may be required by recognized safety standards or by the Occupational Safety and Health Act of 1970 and its subsequent provision.

MG-5301 DC

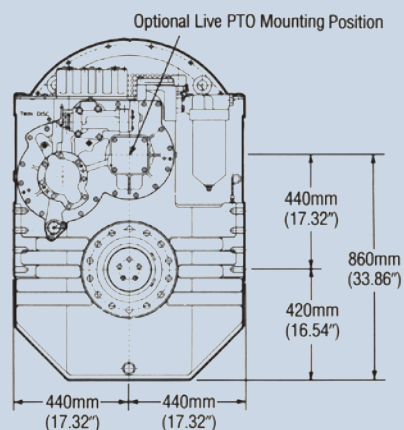
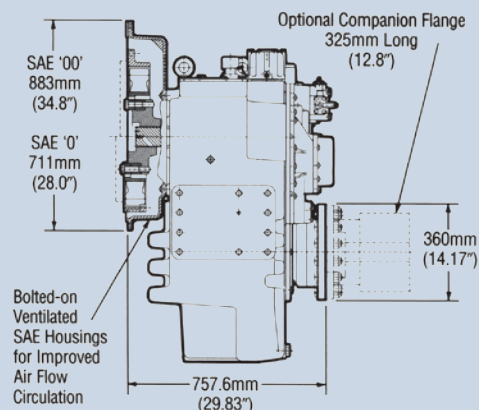

Twin Disc, Incorporated
Racine, Wisconsin 53403 U.S.A
Phone +1-262-638-4000
Fax +1-262-638-4482
www.twindisc.com