

+ + +
+ + +
+ + +
+ + +
+ + +
+ + +
+ + +
+ + +
+ + +
+ + +
+ + +
+ + +
+ + +

CENTAFLEX® SERIES R

HIGHLY FLEXIBLE COUPLINGS
FOR HEAVY DUTY APPLICATIONS



Power Transmission
Leading by innovation

CENTAFLEX®-R

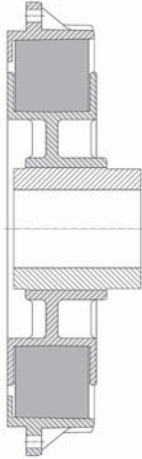

Design



The CENTAFLEX-R is a simple robust ROLLER coupling with a progressive torsional characterisation. Ideal for boat drives, providing a very low stiffness at low torque (& speed) which shifts the torsional resonance below idle speed and prevents gearhammer (gear chatter).

And there are also numerous applications for this kind of coupling in many different industrial drives.

Using the rubber-in-compression principle with rubber rollers between cams, the coupling offers high reliability as it is free from a bonding process common in couplings of equal performance.

The associated cams are profiled using sophisticated computer design (CAD) backed by extensive physical testing.

Important features and advantages of the CENTAFLEX-series R.

- Progressive torsional characteristic with very low stiffness at low torque and increased, but moderate stiffness at high torque
- Fail safe
- Simple, reliable, no bonding, only rubber in compression
- Special developed, temperature resistant elastomer CENTALAN with high damping, suitable for high ambient temperature of more than 100°C (212°F)
- For commercial heavy duty or difficult applications we recommend the special „HD“ rubber rollers, which are also oilresistant.
- Well proven in service and approved by classification societies

- High allowable energy loss by intensive inner and outer ventilation
- Suitable for blind fitting in bell housings
- Economic/easy maintainable design
- Protected by international patents
- Area of application: flange mounted units or well aligned independently mounted units on rigid mounts
- The CF-R is part of the CENTA-Antriebe family of marine drive couplings covering a range between the more than 100 000 times proven CENTAFLEX-DS (Dual Stage) series and the well established, CENTAX series up to 500 kNm.

Technical Data

Centaflex-R size	Rated torque T_k [kNm] for duty:			Max. torque** T_{kmax} [kNm]	Flywheel size SAE J620	Max. speed [rpm]
	pleasure*	intermediate	continuous			
94	0,25	0,20	0,17	0,75	6,5 - 165 and special	5000
114	0,70	0,56	0,49	2,10	11,5 - 290	4000
134	1,00	0,80	0,70	3,00	11,5 - 290	4000
136	1,60	1,25	1,11	4,80	11,5 - 290	4000
216	3,15	2,50	2,20	9,40	11,5 - 290 14 - 355	3500 3000
268	4,25	3,40	3,00	12,50	14 - 355	3000
318	6,30	5,00	4,40	19,00	14 - 355 18 - 460	3000 2600
420	10,00	8,00	7,00	30,00	18 - 460 21 - 530	2600 2300
520	15,00	12,00	10,50	45,00	18 - 460 21 - 530	2600 2300
	*The rated torque for pleasure duty is the nominal torque T_{KN} of the coupling.			**Torque for transient conditions	Other flywheel sizes are available	For higher speeds please consult us

This table shows only the basic technical data required for coupling selection based on engine nominal torque and duty only. We can provide much more detailed technical data, which may be required for the conduction of a torsional vibration analysis. Please ask for data sheet D26-003.

Torsional Responsibility

The responsibility for ensuring torsional compatibility rests with the assembler of the drive train. CENTA cannot accept liability for gearbox noise or for damage of the coupling or other components of the drive caused by torsional vibrations. Torsional vibration analysis can be made by the engine builders, survey societies, consultants etc. or by CENTA.

Dimensional Responsibility

The dimensions on the flywheel side of the couplings are based on standards SAE J620 and DIN 6281, and special flanges. The responsibility for ensuring dimensional compatibility rests with the assembler of the drive train. CENTA cannot accept liability for interference between the coupling and the flywheel or the gearbox or for damage caused by such interference.

We reserve the right to amend any dimension or detail specified or illustrated in this publication without notice and without incurring any obligation

to provide such modification to such couplings previously delivered.

Please ask for an application drawing and current data before making detailed coupling selection.

CENTAFLEX®-R

Dimensions

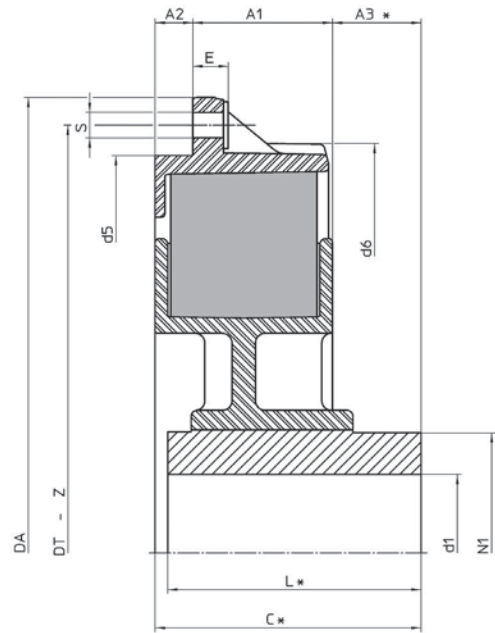

CF-R Size	d1 min-max	N ₁	L*	A ₁	A ₂	A ₃ *	C*	E	d ₅	d ₆	SAE J620	S	Z	D _A	D _T	weight [kg]	Order Code
94	31,75	50	42	32	10	1	36	7,2	148	150	6,5 - 165	9	6x60°	215,9	200	2,4	CF-R-94-06-00000-HR
114	20 - 40	50	47	22,5	24,5	-	47	7,2	208	208	11,5 - 290	11	8x45°	352,4	333,4	3,9	CF-R-114-011-00000-HR
134	30 - 50	70	46	25	22	3	50	11,2	245	245	11,5 - 290	11	8x45°	352,4	333,4	5,5	CF-R-134-011-00000-HR
136	30 - 50	70	46	25	22	3	50	11,2	245	245	11,5 - 290	11	8x45°	352,4	333,4	5,5	CF-R-136-011-00000-HR
216	40 - 60	95	116	50,5	23,5	57	116	16,5	314	313	11,5 - 290 14 - 355	11 13	8x45° 8x45°	352,4 466,7	333,4 438,2	18 19,5	CF-R-216-011-00000-HR CF-R-216-014-00000-HR
268	50 - 90	125	123	47	21	61	130,3	17	409	409	14 - 355	13	8x45°	466,7	438,2	23	CF-R-268-014-00000-HR
318	50 - 90	125	123	68	21	65	155,3	17	409	409	14 - 355 18 - 460	13 17	16x22,5° 12x30°	466,7 571,5	438,2 542,9	25 27	CF-R-318-014-00000-HR CF-R-318-018-00000-HR
420	50 - 115	160	162	90 68	- 22	58	149	36 14	498	511	18 - 460 21 - 530	17 17	12x30° 12x30°	571,5 673,1	542,9 641,4	44 47	CF-R-420-018-00000-HR CF-R-420-021-00000-HR
520	50 - 130	180	194	130	-	56	187	40 50	-	511	18 - 460 21 - 530	17 17	12x30° 24x15°	571,5 673,1	542,9 641,4	48 52	CF-R-520-018-00000-HR CF-R-520-021-00000-HR

* dimensions **C** and **L** can be shortened

Design variations

Standard flange designs are based on SAEJ620c flywheels but special sizes are available upon request.

All shaft designs can be accommodated as the hubs are made of high grade steel and splined, tapered (including oil injection fitted) and parallel shafts can be designed.

Detailed drawings of customized couplings for all important marine gear series are available on request.

Fixed or floating splined input shafts can be accommodated, as the floating spline design has an integral axial location with thrust capacity. Both designs are of the same overall dimensions.

Couplings are uni-directional based on CCW rotation (viewing the flywheel), however sizes 420 and 520 are also available for CW rotation.

The fail safe feature can easily be removed, if it is not wanted.

Application examples:

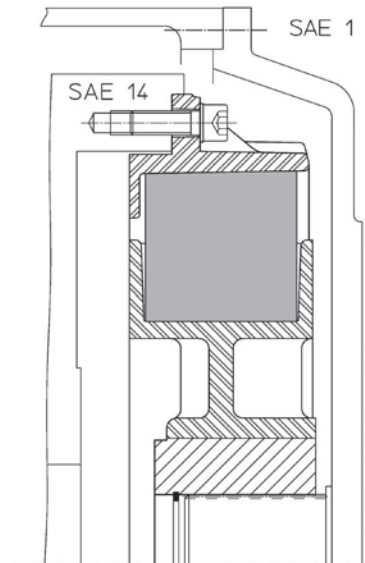
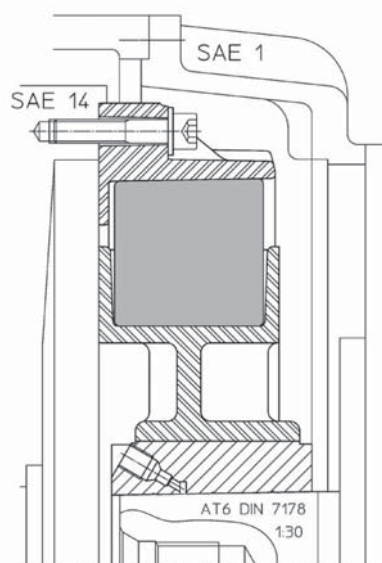

Copyright to this technical document is held by CENTA Antriebe Kirschey GmbH 2000 CENTAX® and CENTAFLEX® ; Registered Trademark of CENTA Antriebe

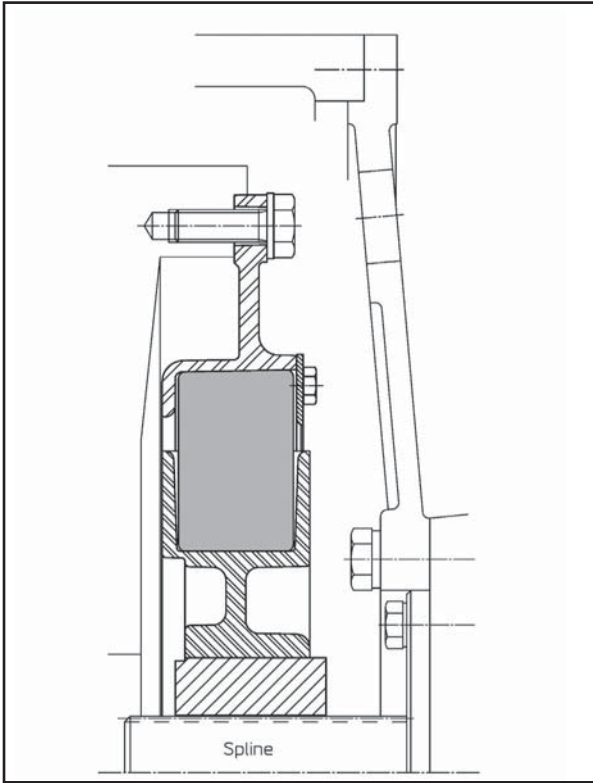

For small gears with splined input shaft, on which the coupling can float axially, a steelplate on the outer flange holds the coupling together axially (sizes 94, 114, 134, 136)

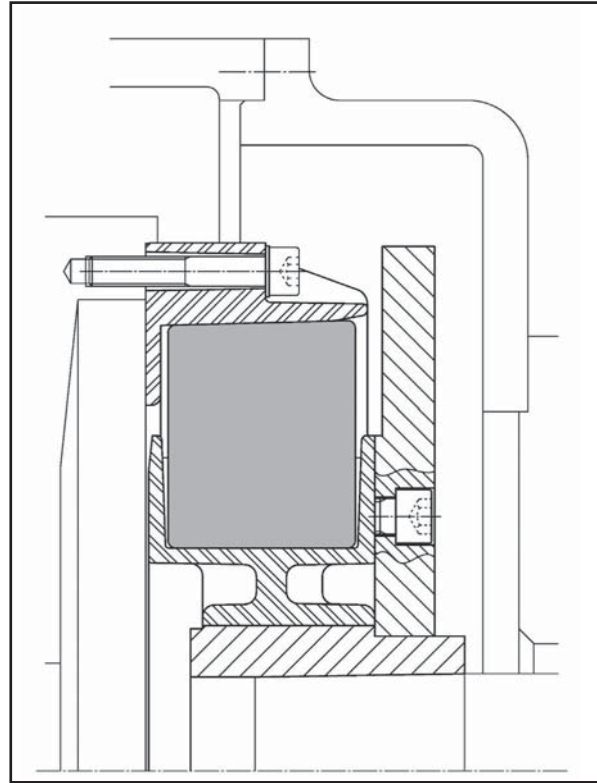

If required by the torsional situation, a steel disc as additional secondary inertia can be added.

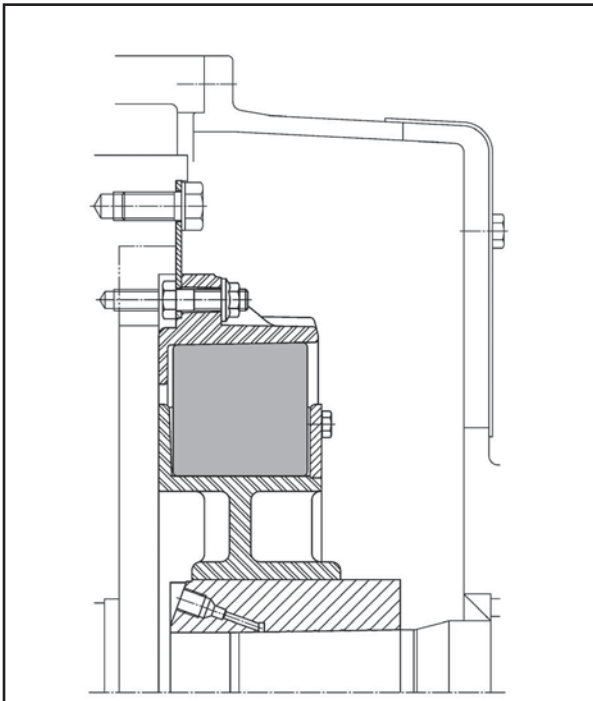

Coupling design for exchange of rollers, normal working conditions. This design is also suitable for free standing, non flanged gears, provided the engine is on rigid mounts and well aligned.

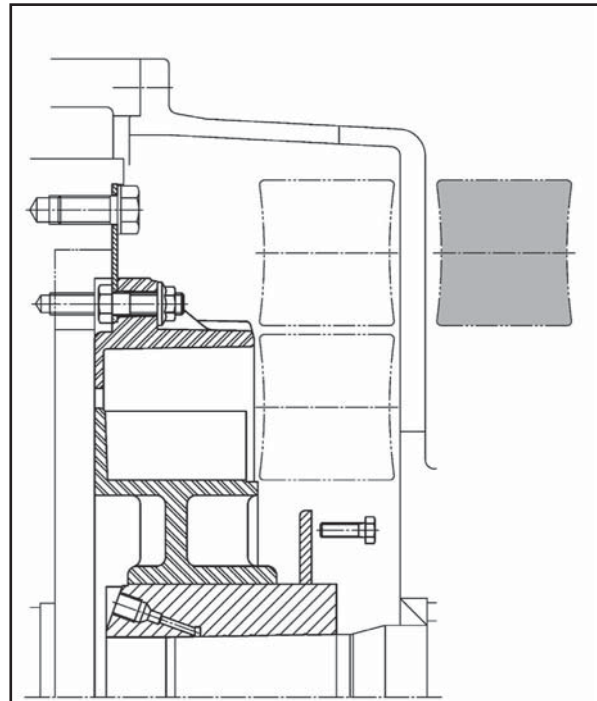

Exchange of rollers. The side plate of the output hub can optionally be bolted on and off. This feature allows easy and quick change of the rubber rollers in situ as well on free standing gears and on flange mounted gears, provided the bell housing offers sufficient space and large enough openings. CENTA can also deliver a spacer for the bell housing in order to provide the necessary space.

CENTA - the complete range of advanced flexible couplings and shafts for all kinds of boat drives.

CENTA Couplings for flange mounted gears



CENTAMAX-S
linear disc type coupling
T = 0,25 - 40 kNm



CENTAFLEX-DS
progressive dual stage coupling
T = 0,25 - 2 kNm

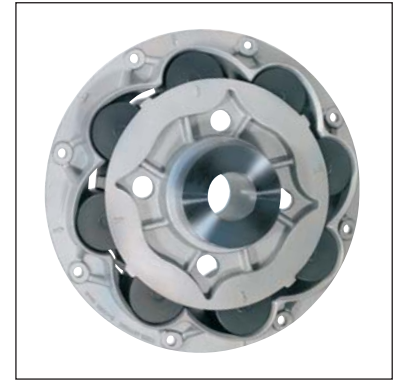

CENTAFLEX-R
progressive roller coupling
T = 0,25 - 15 kNm

Free standing gears - close coupled



CENTAMAX-B
for slight misalignment
T = 0,25 - 20 kNm



CENTAX-N
for reasonable misalignment
T = 1,1 - 25 kNm

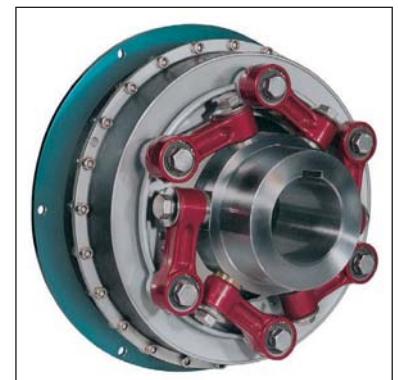

CENTAX-L
for substantial misalignment
T = 2 - 90 kNm

CENTA Couplings for remote mounted gears, V-drives, stern-drives and water jets



CENTAX-V
intermediate coupling for u/j
T = 0,2 - 50 kNm

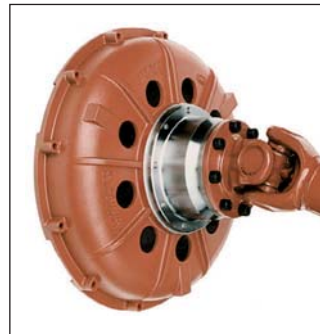

CENTA-FH flange housing
with flexible coupling for u/j
T = 1 - 20 kNm



CENTAFLEX-A-G/A-GZ/A-GS
torsional soft flexible shaft for angle up to 2° per element
T = 0,1 - 14 kNm

CENTA also delivers all kinds of flexible couplings and lightweight shafts - with or without propeller thrust - to be installed between gear and propeller or waterjet

CENTA Couplings for large free standing gears

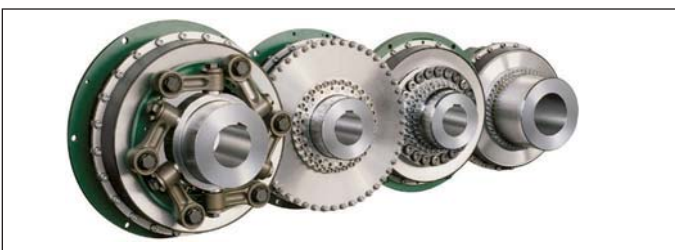

CENTAX - L - G - M - DP
For larger boats and ships CENTA has the complete range of advanced flexible couplings and shafts up to 600 kNm



CENTA ANTRIEBE
Kirschey GmbH

D-42755 Haan P.O.B 1125
Telefon: +49-(0)21 29-912-0
e-mail: centa@centa.de

Bergische Strasse 7
Fax: +49-(0)21 29-2790
<http://www.centa.de>



CENTA Australia



CENTA Denmark



CENTA Headquarters Germany



CENTA Netherland



CENTA Norway



CENTA Italy



CENTA Great Britain



CENTA Singapore



CENTA USA

CENTA the international service

Subsidiaries

Australia
CENTA Transmissions Pty. Ltd.
155 East Kurrajong Road
Kurrajong, NSW 2758

France
Prud'Homme
Transmissions
66 Rue des St. Denis
B.P. 73
F-93302 Aubervilliers Cedex

Japan
Miki Pulley Co.Ltd.
1-39-7, Komatsubara
Zama-City, Kanagawa
JAPAN 228-857

Singapore
CENTA TRANSMISSIONS
FAR EAST PTE LTD
51 Bukit Batok Crescent
#05-24 Unity Centre
Singapore 658077

Austria
Hainzl Industriesysteme GmbH
Industriezeile 56
A-4040 Linz

Germany
CENTA Antriebe
Kirschev GmbH
Bergische Str. 7
D-42781 Haan

Korea
Marine Equipment Korea Co. Ltd.
#509, Dongnam Officetel
104-10 Kuro Dong
Kuro Ku, Seoul

South Africa
Entramarc (PTY) Ltd.
P.O. Box 69189
2021 Bryanston
ZA - Transvaal

Belgium
Caldic Techniek Belgium N.V.
Tollaen 73
B-1932 Sint-Stevens-Woluwe

Great Britain
CENTA Transmissions Ltd.
Thackley Court,
Thackley Old Road,
Shipley, Bradford,
West Yorkshire, BD18 1BW

Mexico
CENTA CORP.
815 Blackhawk Drive
Westmont, IL 60559, USA

Spain
Herrekor S.A.
Zamoka Lantegialdea
Oialume Bidea 25, Barrio Ergobia
ES-20116 Astigarraga-Gipuzkoa

Brazil
CENTA Transmissoes Ltda.
Rua José Américo
Cançado Bahia 199
Cidade Industrial
32.210-130 Contagem MG

Greece
Industry: Kitko S.A.
Marine: Technava S.A.
1, Rodon St. 6,Loudovikou Sq.
17121 N.Smyri 18531 Piraeus
Athens

Netherlands
CENTA Nederland b.v.
Nijverheidsweg 4
NL-3251 LP Stellendam

Sweden
CENTA Transmission Sweden AB
Metalgatan 21A
S-26272 Ängelholm

Canada
CENTA CORP.
815 Blackhawk Drive
Westmont, IL 60559, USA

Hong Kong/China
Foilborn Enterprise Ltd.
Unit A8-9, 13/F
Veristrong Industrial Centre
34-36 Au Pui Wan Street
Fotan, Shatin
N.T. Hong Kong

New Zealand
Brevini Ltd.
UNIT P, 150 Harris Rd.
East Tamaki
PO Box 58-418 - Greenmount
NZ-Auckland

Switzerland
Hainzl Industriesysteme AG
Chamerstrasse 172
CH-6300 Zug

Chile
Comercial TGC Ltda.
Calle Dr. M. Barros Borgoño 255-263
Casilla 16.800 (P.O. Box)
Santiago-Providencia

Norway
CENTA transmisjoner A.S.
Breiliveien 47B
N-3217 Sandefjord

Taiwan
ACE Pillar Trading Co., Ltd.
No. 2 Lane 61, Sec. 1.
Kuanfu Road, San-Chung City, R.O.C.
Taipei

China
CENTA Representative Office
13 B, AiHe Mansion,
No. 629 Ling Ling Road
Shanghai, PC200030

India
NENCO
National Engineering Company
J-225, M.I.D.C., Bhosari,
Pune - 411 026

Poland
Industry: IOW POLSKA
Marine: FBSM
Sp.z.o.o. Engineering & Co.
Ul. Kawaleryjska 8 UL.Podmokla 3
59-220 Legnica 71-776 Szczecin

Turkey
Industry:
Erler Makina ve Gida Sanayi Ltd.Sti.
Ivedik
Organize Sanayi
Has Emek Sitesi 676. Sokak No. 3
Ostim/Ankara

Denmark
CENTA Transmissioner A/S
A.C. Illums Vej 5
DK-8600 Silkeborg

Israel
Redco Equipment & Industry
3, Rival Street
Tel Aviv 67778
IL - Tel Aviv

Portugal
PINHOL Import Dep.
Avenida 24 de Julho, 174
P - LISBOA 1350

USA
CENTA CORP.
815 Blackhawk Drive
Westmont, IL 60559

Egypt
Hydraulic Misr
P.O. Box 418
Tenth of Ramadan City

Italy
CENTA Transmissions Srl
Viale A. De Gasperi, 17/19
I-20020 Lainate (Mi)

CENTA Antriebe is also represented in:
Bulgaria, CSFR, Hungaria, Jugoslavia,
Romania and further countries.



CENTA ANTRIEBE

Kirschev GmbH

D-42755 Haan P.O.B 1125
tel.: +49-(0)21 29-912-0
e-mail: centa@centa.de

Bergische Strasse 7
Fax: +49-(0)21 29-2790
http://www.centa.de